

000 A00 Non Contacting Cleaning Unit HCR-120

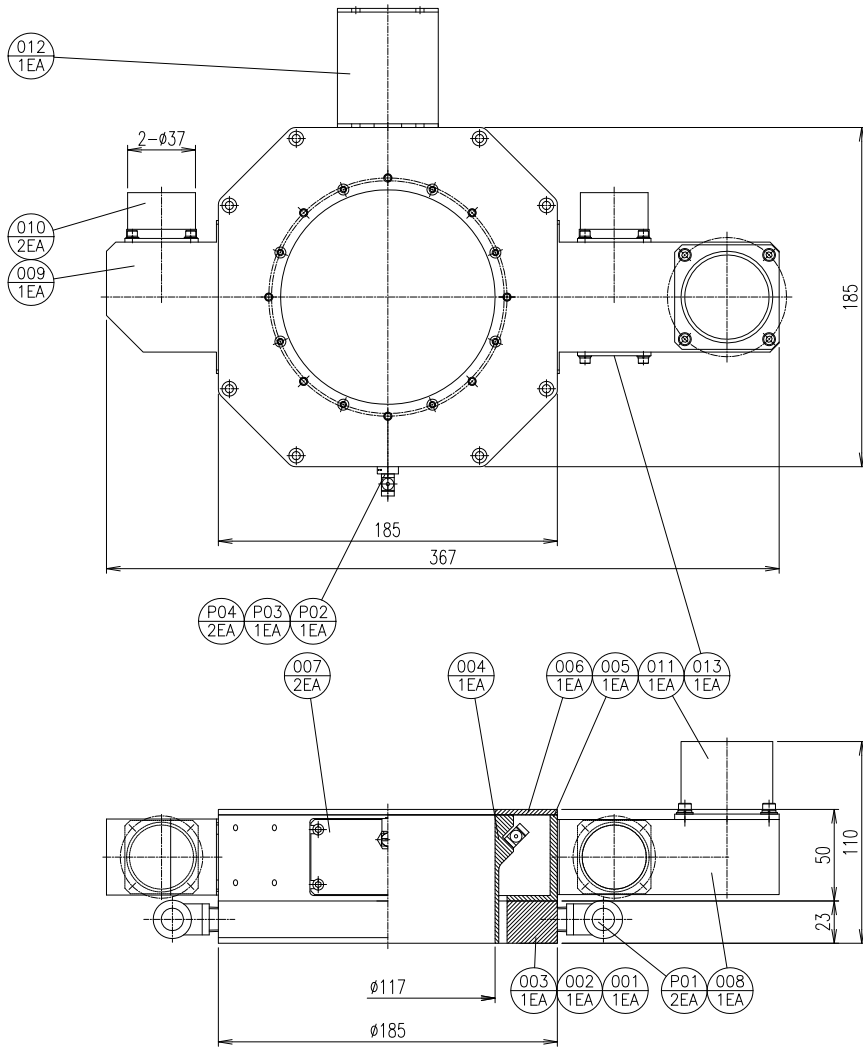

No.	품명	도번	수량		재질	후처리	비고
			Unit	Total			
001	RING BLADE BODY	NTK16-R75P-A00-001-0	.	1	AL6061	BLACK ANODIZING	
002	TOP CAP	NTK16-R75P-A00-002-0	.	1	AL6061	BLACK ANODIZING	
003	SHIM PLATE	NTK16-R75P-A00-003-0	.	1	SUS304H	.	
004	SUCTION GUIDE	NTK16-R75P-A00-004-0	.	1	ACETAL(BLACK)	.	
005	SUCTION CHAMBER	NTK16-R75P-A00-005-0	.	1	AL6061	BLACK ANODIZING	
006	CHAMBER COVER	NTK16-R75P-A00-006-0	.	1	AL6061	BLACK ANODIZING	
007	BLANKING PLATE	NTK16-R75P-A00-007-0	.	2	AL6061	BLACK ANODIZING	
008	EXHAUST MANIFOLD	NTK16-R75P-A00-008-0	.	1	AL6061	BLACK ANODIZING	
009	EXHAUST PORT	NTK16-R75P-A00-009-0	.	1	AL6061	BLACK ANODIZING	
010	EXHAUST PIPE	NTK16-R75P-A00-010-0	.	2	AL6061	BLACK ANODIZING	
011	EXHAUST PIPE	NTK16-R75P-A00-011-0	.	1	AL6061	BLACK ANODIZING	
012	HOSE BRACKET	NTK16-R75P-A00-012-0	.	1	SUS304	전색연마	
013	BLANK PLATE	NTK16-R75P-A00-013-0	.	1	AL6061	BLACK ANODIZING	
014	
015	

No.	품명	수량		규격	업체명
		Unit	Total		
P01	FITTING	.	2	KQ2L12-025	SMC
P02	FITTING	.	1	M-5E	SMC
P03	FITTING	.	1	KQ2T04-M5	SMC
P04	FITTING	.	2	M-5HLH-4	SMC
P01

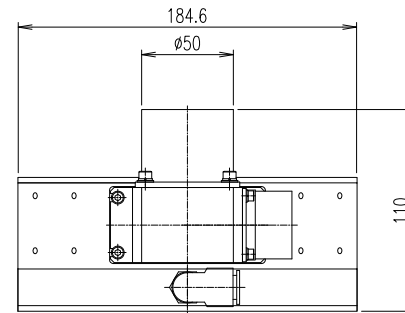
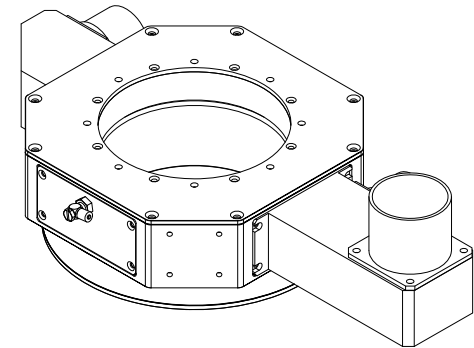

일반 공차			
표준 규격	정밀도	표명	공차
. X	0.1	VV	0.3 S
. XX	0.01	VV	25 S
		V	100 S
최소 규격	1급	2급	3급
0.05-0.8	0.05	0.10	0.20
0.8-3.0	0.10	0.20	0.50
3.0-12.0	0.15	0.30	0.80
12.0-30.0	0.20	0.50	1.20
30.0-100.0	0.30	0.80	2.00
100.0+	0.50	1.20	3.00
표준 기	0.3	0.5	1.0
정밀 기	0.2	0.5	1.0
방열 기	0.10	0.15	0.20
특 정 기	0.10	0.15	0.20
HOLE-FITTING	0.15	0.20	0.30

NO.	REVISIONS	NAME	DATE
△	-	-	-
△	-	-	-

No.	품명	도번	수량		재질	후처리	비고
			Unit	Total			
.
Project			-		Part	-	
제도			-		Unit	-	
설계			BM JIN		2016.04.25		
검도			-		Scale	1/1	
승인			-		-		
KIND (1. Ass'y 2. Sub ass'y 3. Parts 4. Other)					Non Contacting Cleaning Unit HCR-120		
DWG No.					NTK15-R120-A00-000-0		
SH No.					/		

NTK (주)엔티케이코퍼레이션