

No.	품명	도번	수량		재질	후처리	비고
			Unit	Total			
001	RING BLADE BODY	NTK17-R90-A00-001-0	.	1	AL6061	BLACK ANODIZING	
002	TOP CAP	NTK17-R90-A00-002-0	.	1	AL6061	BLACK ANODIZING	
003	SHIM PLATE	NTK17-R90-A00-003-0	.	2	SUS304H	.	
004	SUCTION GUIDE	NTK17-R90-A00-004-0	.	1	AL6061	BLACK ANODIZING	
005	SUCTION CHAMBER	NTK17-R90-A00-005-0	.	1	AL6061	BLACK ANODIZING	
006	CHAMBER COVER	NTK17-R90-A00-006-0	.	1	AL6061	BLACK ANODIZING	
007	EXHAUST PORT	NTK17-R90-A00-007-0	.	2	AL6061	BLACK ANODIZING	
008	EXHAUST PIPE	NTK17-R90-A00-008-0	.	2	AL6061	BLACK ANODIZING	
009	BLANKING PLATE	NTK17-R90-A00-009-0	.	2	AL6061	BLACK ANODIZING	
010	.	.	.	.	.	.	.
011	.	.	.	.	.	.	.
012	.	.	.	.	.	.	.

No.	품명	수량		규격	업체명
		Unit	Total		
P01	FITTING	.	2	KAL10-U02	.-
P02	FITTING	.	3	M-5HLH-4	SMC
P03	FITTING	.	1	M-5E	SMC
P04	FITTING	.	1	KQ2T04-M5	SMC
.	.	.	.	.	.

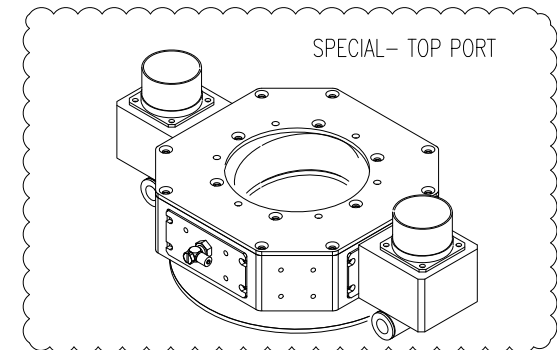
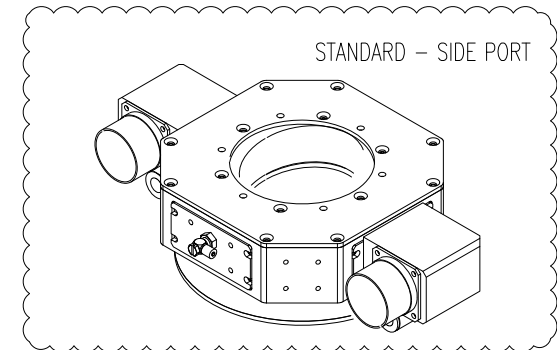

NO.	REVISIONS	NAME	DATE
△	-	-	-
△	-	-	-

일반 공차			
수치 범위	정밀도	표준 코드	
. X	0.1	VVY	0.5 S
. XX	0.01	VVY	25 S
특수 공차	1급	2급	3급
0.05-0.08	0.05	0.10	0.20
0.1-0.20	0.10	0.20	0.50
0.2-0.30	0.15	0.30	0.80
0.3-0.45	0.20	0.50	1.20
0.45-0.60	0.30	0.80	2.00
0.6-0.80	0.40	1.20	3.00
0.8-1.0	0.50	1.50	4.00
1.0-1.5	0.60	2.00	5.00
1.5-2.0	0.70	2.50	6.00
2.0-3.0	0.80	3.00	7.00
3.0-4.0	0.90	3.50	8.00
4.0-5.0	1.00	4.00	9.00
5.0-7.0	1.10	4.50	10.00
7.0-10.0	1.20	5.00	11.00
10.0-15.0	1.30	5.50	12.00
15.0-20.0	1.40	6.00	13.00
20.0-30.0	1.50	6.50	14.00
30.0-40.0	1.60	7.00	15.00
40.0-50.0	1.70	7.50	16.00
50.0-70.0	1.80	8.00	17.00
70.0-100.0	1.90	8.50	18.00
100.0-150.0	2.00	9.00	19.00
150.0-200.0	2.10	9.50	20.00
200.0-300.0	2.20	10.00	21.00
300.0-400.0	2.30	10.50	22.00
400.0-500.0	2.40	11.00	23.00
500.0-700.0	2.50	11.50	24.00
700.0-1000.0	2.60	12.00	25.00

No.	품명	도번	수량		재질	후처리	비고
			Unit	Total			
.	.	.	.	.	.	.	.
.	.	.	.	.	.	.	.
.	.	.	.	.	.	.	.
.	.	.	.	.	.	.	.
.	.	.	.	.	.	.	.

Project		Part	
제도	.	Unit	.
설계	HJ LEE	Scale	1/1
검도	.	Non Contacting Cleaning Unit HCR-90	
승인	.	KIND ( 1. Ass'y 2. Sub ass'y 3. Parts 4. Other )	
DWG No.		SH No.	
NTK17-HCR90-A00-00			