

000 A00 Non Contacting Cleaning Unit HCS-60x60 without Nozzle Blow

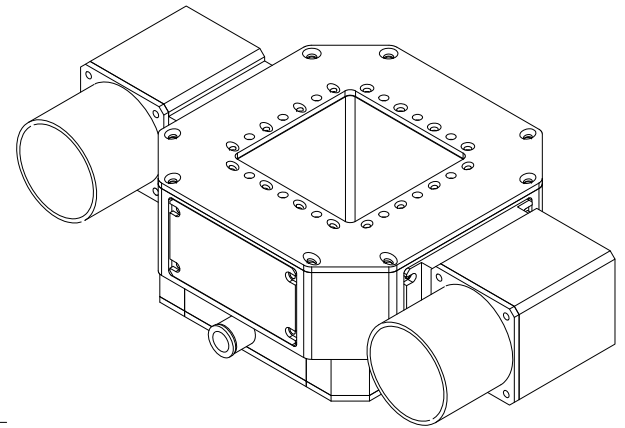
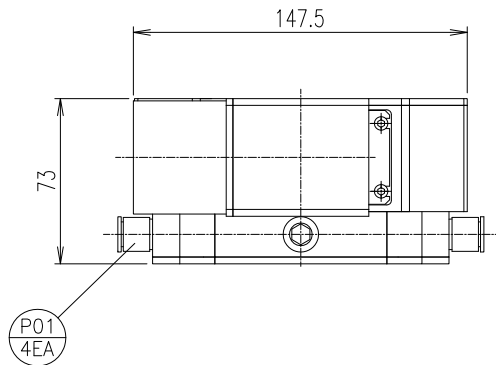
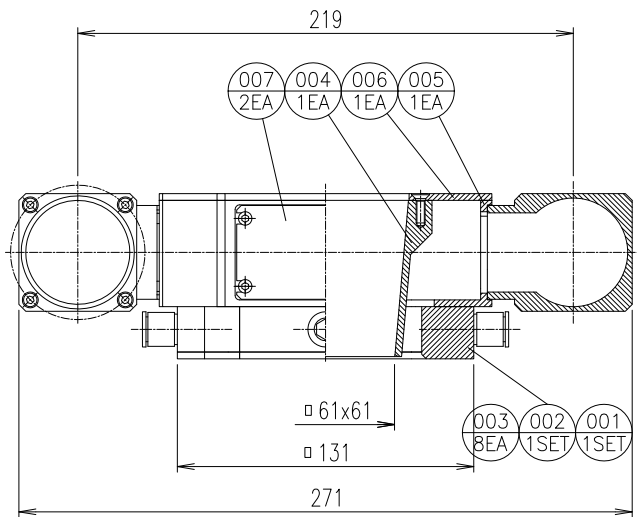
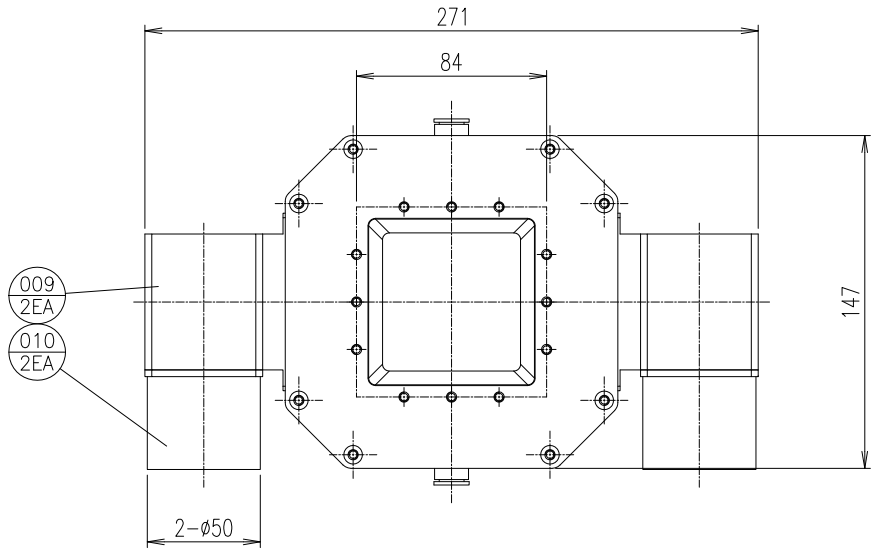

No.	품명	도번	수량		재질	후처리	비고
			Unit	Total			
001	RING BLADE BODY	NTK16-HCS60-A00-001-0	SET	1	AL6061	BLACK ANODIZING	.
002	TOP CAP	NTK16-HCS60-A00-002-0	SET	1	AL6061	BLACK ANODIZING	대면행지처리
003	SHIM PLATE	NTK16-HCS60-A00-003-0	.	8	SUS304H	.	.
004	SUCTION GUIDE	NTK16-HCS60-A00-004-0	.	1	AL6061	BLACK ANODIZING	.
005	SUCTION CHAMBER	NTK16-HCS60-A00-005-0	.	1	AL6061	BLACK ANODIZING	GLASS SENDING
006	CHAMBER COVER	NTK16-HCS60-A00-006-0	.	1	AL6061	BLACK ANODIZING	GLASS SENDING
007	BLANKING PLATE	NTK16-HCS60-A00-007-0	.	2	AL6061	BLACK ANODIZING	GLASS SENDING
008
009	EXHAUST PORT	NTK16-HCS60-A00-008-0	.	2	AL6061	BLACK ANODIZING	GLASS SENDING
010	EXHAUST PIPE	NTK16-HCS60-A00-010-0	.	2	AL6061	BLACK ANODIZING	GLASS SENDING
011
012
013
014
015

No.	품명	수량		규격	업체명
		Unit	Total		
P01	FITTING	.	4	KQ2S10-02NS	SMC
.
.
.
.
.

일반공차		
표준공차	정밀차	표명코드
. X	0.1	VV V 8.3 S
. XX	0.01	VV V 25 S
특수공차		
1급	2급	3급
0.05	0.10	0.20
0.10	0.20	0.50
0.15	0.30	0.80
0.20	0.50	1.20
0.30	0.80	2.00
0.50	1.20	3.00
표준기		
0.3	0.5	1.0
0.5	0.8	1.5
0.10	0.15	0.20
0.10	0.15	0.20
0.15	0.20	0.30

NO.	REVISIONS	NAME	DATE
△	-	-	-
△	-	-	-

No.	품명	도번	수량		재질	후처리	비고
			Unit	Total			
.
.
.
.
.
.
Project: - Part: -							
설계: HJ LEE, 2016.10.31 Unit: -							
Scale: 1/1 Non Contacting Cleaning Unit HCS-60x60							
KIND (1. Ass'y 2. Sub ass'y 3. Parts 4. Other)							
DWG No. NTK16-HCS60-A00-R2 SH No. /							

NTK (주)엔티케이코퍼레이션