

000 A00 Non Contacting Cleaning Unit HCS-90x90

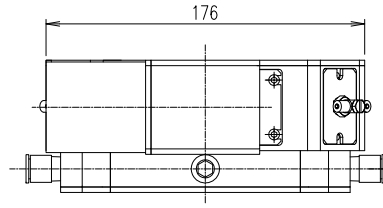

No.	품명	도번	수량		재질	후처리	비고
			Unit	Total			
001	RING BLADE BODY	NTK16-HCS90-A00-001-0	SET	1	AL6061	BLACK ANODIZING	.
002	TOP CAP	NTK16-HCS90-A00-002-0	SET	1	AL6061	BLACK ANODIZING	대전방지처리
003	SHIM PLATE	NTK16-HCS90-A00-003-0	EA	8	SUS304H	.	.
004	SUCTION GUIDE	NTK16-HCS90-A00-004-0	EA	1	AL6061	BLACK ANODIZING	.
005	SUCTION CHAMBER	NTK16-HCS90-A00-005-0	EA	1	AL6061	BLACK ANODIZING	GLASS SENDING
006	CHAMBER COVER	NTK16-HCS90-A00-006-0	EA	1	AL6061	BLACK ANODIZING	GLASS SENDING
007	BLANKING PLATE	NTK16-HCS90-A00-007-0	EA	2	AL6061	BLACK ANODIZING	GLASS SENDING
008	FITTING PLATE	NTK16-HCS90-A00-008-0	EA	4	AL6061	BLACK ANODIZING	GLASS SENDING
009	EXHAUST PORT	NTK16-HCS90-A00-008-0	EA	2	AL6061	BLACK ANODIZING	GLASS SENDING
010	EXHAUST PIPE	NTK16-HCS90-A00-010-0	EA	2	AL6061	BLACK ANODIZING	GLASS SENDING
011
012
013
014
015

No.	품명	수량		규격	업체명
		Unit	Total		
P01	FITTING	.	4	KQ2S10-02NS	SMC
P02	FITTING	.	4	M-5E	SMC
P03	FITTING	.	4	KQ2LU04-M5	SMC
P04	FITTING	.	12	M-5HLH-4	SMC
.

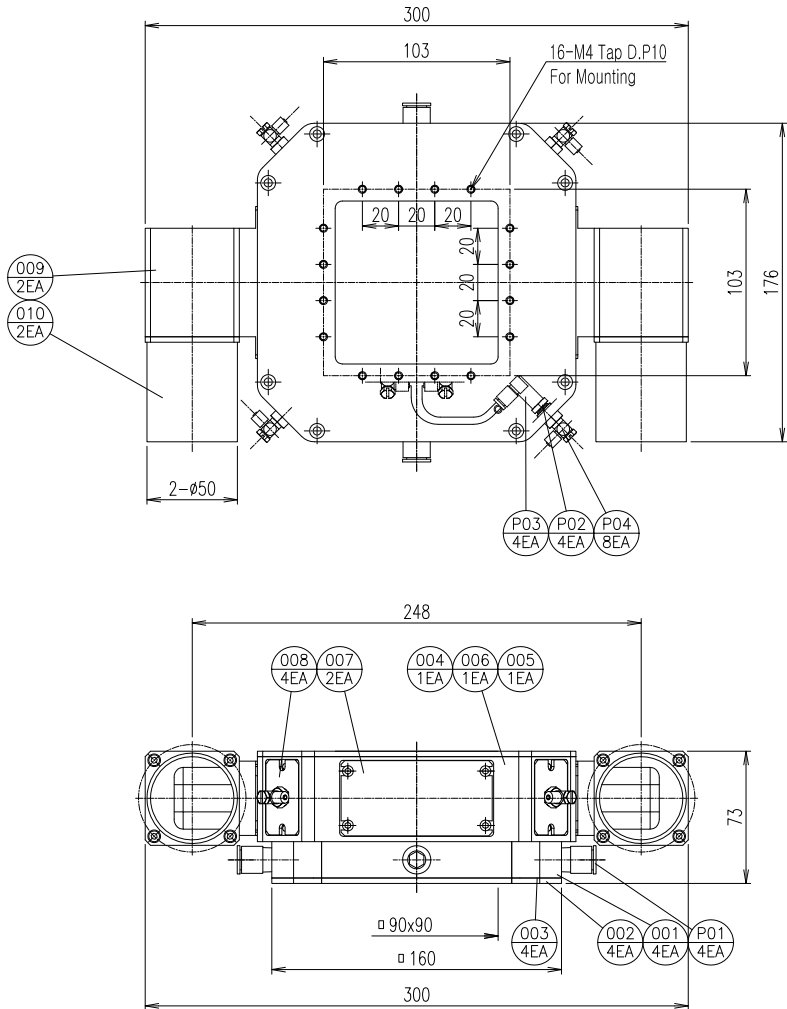
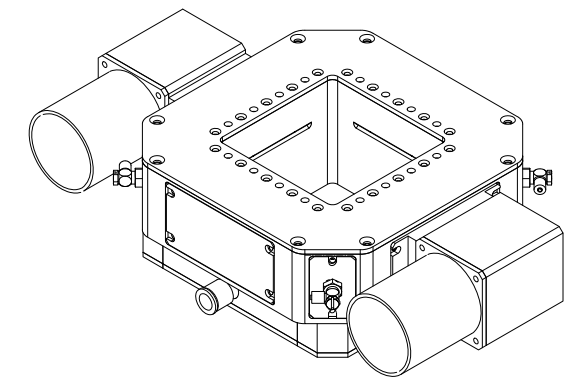

일반공차			
수치표기법	단위	표준공차	표준공차
. X	0.1	VVY	0.3 S
. XX	0.01	VVY	25 S
. XXX	0.001	VVY	100 S
각수공차			
	1급	2급	3급
0.5~1.0	0.05	0.10	0.20
1.0~3.0	0.10	0.20	0.50
3.0~10.0	0.15	0.30	0.80
10.0~30.0	0.20	0.50	1.20
30.0~100.0	0.30	0.80	2.00
100.0~1.000.0	0.50	1.20	3.00
표준기			
	0.3	0.5	1.0
	0.2	0.5	1.0
방열	0.10	0.15	0.20
각도	0.10	0.15	0.20
HOLE-FITTING	0.15	0.20	0.30

NO.	REVISIONS	NAME	DATE
△	-	-	-
△	-	-	-

No.	품명	도번	수량		재질	후처리	비고
			Unit	Total			
.
Project			-		Part	-	
설계			HJ LEE		Unit	-	
검도			2016.09.29		Scale	1/1	
승인			-		Non Contacting Cleaning Unit HCS-90x90		
KIND (1. Ass'y 2. Sub ass'y 3. Parts 4. Other)						DWG No.	
NTK (주)엔티케이코퍼레이션						NTK16-HCS90-A00-00	
						SH No.	
						/	